



National Electric Power Regulatory Authority
Islamic Republic of Pakistan

NEPRA Tower, Attaturk Avenue (East), G-5/1, Islamabad
Ph: +92-51-9206500, Fax: +92-51-2600026
Web: www.nepra.org.pk, E-mail: registrar@nepra.org.pk

Registrar

No. NEPRA/R/DL/LAG-375/ *6024-29*

May 02, 2017

Mr. Ch. Khan M. Ashraf
Chief Executive
Bahawalpur Energy Limited (BPREL)
Upper Mall, Lahore, Pakistan.
Phone. +92-42-35718333-555

Subject: Grant of Generation Licence No. IGSPL/77/2017
Licence Application No. LAG-375
Bahawalpur Energy Limited (BPREL)

Reference: Your application vide letter No. BWEL/12/2016/016, dated December 21, 2016 (received on December 22, 2016).

Enclosed please find herewith Determination of the Authority in the matter of Application of Bahawalpur Energy Limited (BPREL) for the Grant of Generation Licence along with Generation Licence No. IGSPL/77/2017 annexed to this determination granted by the National Electric Power Regulatory Authority (NEPRA) to BPREL for its 31.20 MW Bagasse based Co-Generation Facility located at Ashrafabad, Tehsil & District Bahawalpur, in the province of Punjab, pursuant to Section 15 of the Regulation of Generation, Transmission and Distribution of Electric Power Act (XL of 1997).

2. Please quote above mentioned Generation Licence No. for future correspondence.

Enclosure: Generation Licence
(IGSPL/77/2017)

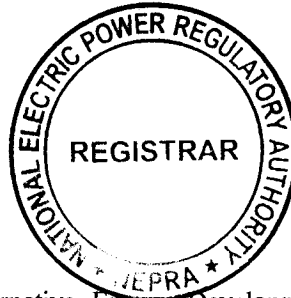

Handwritten signature and date: 27/5/17
(Syed Safer Hussain)

Copy to:

1. Chief Executive Officer, Alternative Energy Development Board (AEDB), 2nd Floor, OPF Building, G-5/2, Islamabad.
2. Chief Executive Officer, NTDC, 414-WAPDA House, Lahore.
3. Chief Executive Officer, CPPA-G, ENERCON Building, Sector G-5/2, Islamabad.
4. Chief Executive Officer, Multan Electric Power Company (MEPCO), NTDC Colony, Khanewal Road, Multan.
5. Director General, Environment Protection Department, Government of Punjab, National Hockey Stadium, Ferozepur Road, Lahore.

National Electric Power Regulatory Authority
(NEPRA)

Determination of the Authority
in the Matter of Application of Bahawalpur Energy Limited
for the Grant of Generation Licence

April 24, 2017
Case No. LAG-375

(A). Background

(i). In order to commercially harness the potential of the Renewable Energy (RE) Resources in the country, the Government of Pakistan (GoP) has set up Alternative Energy Development Board (AEDB) as one window facilitator for the potential investors.

(ii). In this regard, AEDB has formulated "the Policy for Development of Renewable Energy for Power Generation 2006" ("the RE Policy"). Initially, the scope of the RE Policy included development of Hydro, Wind, and Solar technologies. Later on, GoP amended the scope of the RE Policy to include power projects based on Bagasse, Biomass, Waste-to-Energy and Bio-Energy. Further, GoP also extended the applicability of the Policy for an additional five years w.e.f. March 06, 2013. According to the said amendments, High-Pressure (minimum 60 bar) Bagasse/Bio-Mass based projects are envisaged to be set up as part of an existing sugar mill or as a separate entity. In consideration of the said, AEDB has issued Letter of Intent (LoI) to different entrepreneurs/power developers including Bahawalpur Energy Limited (BPREL), for setting up a 31.20 MW Bagasse based power project at Ashraf Abad, Tehsil and District Bahawalpur, in the province of Punjab.

(iii). According to the terms and conditions of the LoI, the sponsors of the project (i.e. Ashraf Sugar Mills Limited-ASML and other individuals) were required to approach the Authority for the grant of generation licence and acceptance of the already determined up-front tariff.

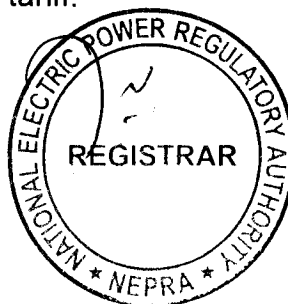

(B). Filing of Application

(i). In accordance with Section-15 of Regulation of Generation, Transmission and Distribution of Electric Power Act, 1997 ("the NEPRA Act"), BPREL submitted an application on December 22, 2016 requesting for the grant of generation licence.

(ii). The Registrar examined the submitted application to confirm its compliance with the NEPRA Licensing (Application and Modification Procedure) Regulations, 1999 ("the Licensing Regulations") and observed that the application lacked some of the required information/documentation. Accordingly, BPREL was directed for submitting the missing information/documentation and the same was submitted on January 06, 2017. The Authority considered the matter and found the form and content of the application in substantial compliance with Regulation-3 of the Licensing Regulations. Accordingly, the Authority admitted the application for consideration of the grant of the generation licence as stipulated in Regulation-7 of the Licensing Regulations. The Authority approved the advertisement containing the prospectus and a notice to the general public about the admission of the application of BPREL, inviting to submit their comments in the matter as stipulated in Regulation-8 of the Licensing Regulations. The Authority also approved the list of the relevant stakeholders for providing their comments or otherwise to assist the Authority in the matter. Accordingly, the advertisement was published in one Urdu and one English National newspapers on January 27, 2017 respectively.

(iii). Apart from the above, separate letters were also sent to Government Ministries, their attached departments, representative organizations and individual experts etc. on January 30, 2017. The said stakeholders were directed for submitting their views/comments for the assistance of the Authority.

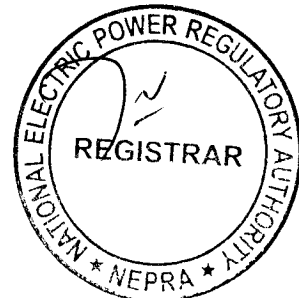

(C). Comments of Stakeholders

(i). In reply to the above, the Authority received comments from three (03) stakeholders. These included Ministry of Climate Change (MoCC), Ministry of Petroleum & Natural Resources (MoP&NR) and Anwar Kamal Law Associates (AKLA). The salient points of the comments offered by the said stakeholders are summarized below:-

- (a). MoCC stated that it receives copies of letters regarding the grant of generation licence to various companies. A details regarding total number of such licences issued so far including their names, location, generation capacity, type of fuel to be used and other relevant information may be provided for reference and record;
- (b). MoP&NR commented that the documents pertaining to the application of BPREL show that no fuel source (oil, gas or coal) other than bagasse will be used for the proposed generation facility/power plant. Therefore, the matter does not appear to involve this Ministry;
- (c). AKLA highlighted different issues pertaining to the power sector of the country including (a). surplus capacity; (b) underutilization of power plants; and (c). induction of new power plants on "Take or Pay basis" etc. Further, AKLA contested that RE power plants are not viable financially and economically due to higher upfront tariff and "must run condition". AKLA also questioned the induction of RE projects in the current scenario (i.e. reduction in oil prices, RLNG contract with Qatar, upcoming coal power projects and introduction of competitive market etc.),





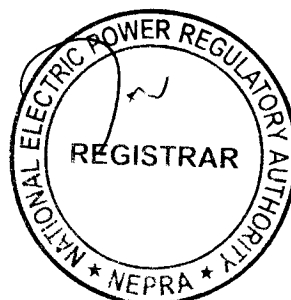

affordability vs. availability of electric power and long term Power Purchase Agreements (PPAs) on "Take or Pay" basis etc. AKLA stated that it is not against setting up new power plants and in this regard, a very careful estimate of required generation capacities should be made or the licences should be granted on "Take and Pay" basis.

(ii). The Authority considered the above comments of the stakeholders and directed the Registrar to provide the required information to MoCC however, no further comments were received. Further, on the observations of AKLA the Authority decided to seek the perspective of BPREL. In reply to the said, BPREL submitted that points raised by AKLA mainly relate to the policies of GoP for promotion of RE in the country. BPREL stated that AKLA has submitted its comments without fully appreciating the dynamics of the project, energy sector, financial and technical considerations relevant for determining project parameters.

(iii). BPREL submitted that the biggest concern expressed by AKLA is that the projects are being planned on "Take or Pay" and the same may be changed to "Take and Pay". The current structure of the power sector is of single buyer having regulated tariffs. The structure suffers from various issues particularly that of the payment to producers of the energy supplied. Therefore, till such time a flawless mechanism and market structure is introduced which protects the interest of the power producer in terms of their ability to meet their fixed costs, a "Take and Pay" tariff structure for power projects is not bankable.

(iv). Further to the above, BPREL submitted that the greater use of indigenous resources especially RE, can help diversify the energy mix of the country. This will reduce the dependence on imported fossil fuels, thereby mitigating the supply disruptions and price fluctuation risks. The projects being set up by sugar mills using Bagasse as fuel are virtually foreign currency neutral as all the fuel is generated and procured locally. Further, the projects

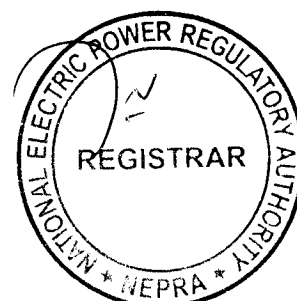

are being financed by local banks in local currency and there is no foreign currency repatriation of dividends since all equity is being contributed by sugar mills in local currency. In case of other projects, the above three factors are expected to put considerable pressure on foreign currency requirement of the country in the future.

(v). BPREL further stated that AKLA in its comments claimed that generation capacity of Pakistan is surplus. It appears that the commentator is not fully aware about the operational capacity and installed capacity, for instance the installed capacity of the hydro projects cannot operate at full load throughout the year as it is dependent on the hydrology. Furthermore, a sizeable portion of installed capacity is inefficient and not economically viable to be operated. With regards to the comparison with furnace oil based projects, BPREL submitted that even in the best scenario of low fuel prices, the furnace oil tariff today is not less than the Bagasse tariff notwithstanding the disadvantage of foreign fuel. In the long run and on a levelized basis, Bagasse tariff is essentially lower. AKLA may also acknowledge that fuel prices are volatile and it cannot be assumed that same will remain on the existing low level.

(vi). BPREL submitted that although there are projects under construction on coal and RLNG fuels however, the ever-increasing demand of electricity will continue to exist. Therefore, it is imperative to maintain a sizeable share of RE in the overall energy mix which will result in savings of precious foreign exchange. BPREL stated that presently Pakistan has the lowest contribution of RE in the energy mix which needs to be improved to the level of other developing countries.

(vii). The Authority considered the above submissions and decided to proceed further in the matter of application of BPREL for the consideration of grant of generation licence as stipulated in the Licensing Regulations and NEPRA Licensing (Generation) Rules 2000 ("the Generation Rules").

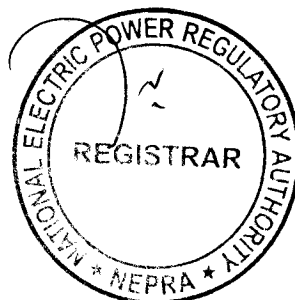

(D). Evaluation of the Case

(i). The Authority has examined the submissions of BPREL including the information provided in its application for the grant of generation licence. The Authority has duly considered the feasibility study of the project, interconnection & dispersal arrangement studies etc., provisions of the RE Policy, the relevant rules & regulations.

(ii). The Authority has observed that main sponsors of the project are ASML and other individuals (collectively the sponsors). In this regard, the Authority has observed that ASML is engaged in the production and sale of sugar (including by-products such as molasses). ASML is amongst the leading sugar mills in the country in terms of sugar production and sucrose recovery. ASML owns, operates and maintains a 12,000 TCD sugar mill located at 23-KM Ahmed Pur East Road Ashrafabad, tehsil and district Bahawalpur in the province of Punjab. As part of the above sugar mill, ASML also owns, operates and maintains a generation facility/Captive Power Plant (CPP) with an installed capacity of 24.50 MW for which the Authority granted a generation licence (No. SGC/57/2010, dated April 29, 2010). ASML is supplying around 10.00-12.00 MW of surplus electric power to MEPCO from the said generation facility through a PPA signed in the year 2008 initially for a term of one (01) year extendable on mutually agreed terms and conditions. It is pertinent that the said PPA has been renewed and ASML is continuously supplying to MEPCO even now.

(iii). According to the provided information, the project company and the sponsors have total assets of around Rs. 10.00 billion. Further, based on the financial strength and other evaluation parameters, AEDB issued Lol for setting up an approximately 31.20 MW Bagasse based generation facility/co-generation facility/power plant within ASML located at 23-KM Ahmed Pur East Road Ashrafabad, tehsil and district Bahawalpur in the province of Punjab. In order to implement the project, the sponsors incorporated a Special Purpose Vehicle (SPV) in the name of BPREL under Section-32 of the Companies

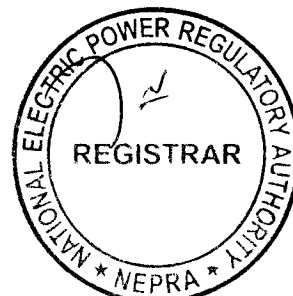

Ordinance, 1984. The Memorandum of Association of the SPV, *inter alia*, includes the business of power generation and sale as one of its business objects. The Authority has observed that SPV/BPREL carried out a feasibility study of the project, *inter alia*, including the proposed equipment for generation facility/co-generation facility/power plant, soil tests reports, technical details pertaining to selected steam turbine generator and other allied equipment, electrical studies, environmental study and project financing etc. According to the feasibility study, the SPV/BPREL will be setting up a 31.20 MW Bagasse based generation facility/co-generation facility/power plant in district Bahawalpur, in the province of Punjab. In this regard, the sponsors have submitted necessary documents confirming that the proposed site of the project is in their name and possession.

(iv). BPREL has confirmed that the proposed generation facility/co-generation facility/power plant will be consisting of 1 x 31.20 MW of steam turbine (extraction cum condensing type) with high pressure (110 bar) travelling grate boilers (with steam generation capacity of 160 TPH). According to the submitted information, the net efficiency of the proposed generation facility/co-generation facility/power plant will be 24.50%. The proposed generation facility/co-generation facility/power plant will be utilizing Bagasse for firing the boiler.

(v). In this regard, the Authority has observed that the proposed generation facility/co-generation facility/power plant will utilize the Bagasse generated from ASML. In this regard, BPREL has confirmed that the Bagasse generated from ASML will be sufficient to operate the proposed generation facility/co-generation facility/power plant to meet with the required plant factor and plant availability as stipulated in the determination of the Authority No. NEPRA/R/TRF-UTB-2013/5152-54, dated May 29, 2013 for the upfront tariff for Bagasse based projects. BPREL has also confirmed that if there is shortage of Bagasse in the area due to change in pattern of crop of sugarcane, either the Bagasse will be purchased from the market or some other bio-mass (including cane trash, cotton stick, mustard straw and rice

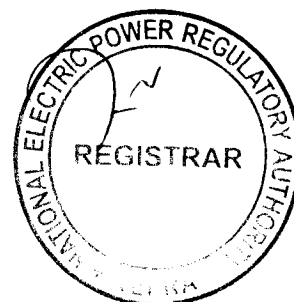

husk etc.) will be utilized for the operation of the generation facility/co-generation facility/power plant. In view of the said, the Authority is satisfied that the project will have the required fuel for the operation of the proposed generation facility/co-generation facility/power plant.

(vi). The Authority has observed that BPREL carried out the required interconnection and system stability study for dispersal of electric power from the proposed generation facility/co-generation power plant. According to the said study, the dispersal of electric power will be made on 132 KV Voltage. The dispersal/interconnection arrangement will be consisting of a 132 KV Double Circuit (D/C) transmission line (on ACSR LYNX Conductor) measuring about eight (08) Kilo-Meter for making an In-Out of 132 KV Bahawalpur (New)-Samma Satta transmission line connecting the proposed generation facility/co-generation facility/power plant of BPREL with the network of MEPCO. In this regard, MEPCO has also confirmed that necessary arrangements will be made ensuring availability of the dispersal arrangement well before the Commercial Operation Date (COD) of the generation facility/co-generation facility/power plant.

(vii). The Authority is encouraged that the proposed project of BPREL will be utilizing Bagasse which is RE source. However, the Authority has observed that the proposed generation facility/co-generation facility/power plant will be working as a conventional thermal power plant using steam turbine for generation of electric power/energy that may cause environmental concerns. In this regard, the Authority has observed that BPREL carried out the Initial Environment Examination Study and submitted the same for the consideration and approval of Environmental Protection Agency, Government of the Punjab (EPAGoPb). The Authority is satisfied that EPAGoPb has issued a No Objection Certificate for the construction of the project.

(viii). In terms of Rule-3 of the Generation Rules, the Authority may grant a generation licence to any person to engage in the generation business. The said rule stipulates various conditions pertaining to the grant of generation

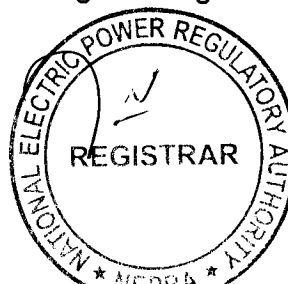

licence as explained in Rule-3(2), Rule-3(3), Rule-3(4), Rule-3(5) and Rule-3(6) of the Generation Rules. In the particular case under consideration, the Authority has observed that conditions of Rule-3(2) and Rule-3(3) stands satisfied as BPREL has provided details of location, technology, size, net capacity/energy yield, interconnection arrangements, technical limits, technical functional specifications and other details specific to the generation facilities. The provision of Rule-3(4) of the Generation Rules regarding holding a public hearing is not attracted as there is no issue which requires deliberation through public participation. The Rule-3(5) of the Generation Rules stipulates that the Authority may refuse to issue a generation licence where the site, technology, design, fuel, tariff or other relevant matters pertaining to the generation facility/co-generation facility/power plant proposed in an application for a generation licence are either not suitable on environmental grounds or do not satisfy the least cost option criteria. In this regard, the Rule-3(5) of the Generation Rules stipulates the conditions pertaining to Least Cost Option Criteria which includes (a). sustainable development or optimum utilization of the RE or non-RE resources proposed for generation of electric power; (b). the availability of indigenous fuel and other resources; (c). the comparative costs of the construction, operation and maintenance of the proposed generation facility/co-generation facility/power plant against the preferences indicated by the Authority; (d). the costs and right-of-way considerations related to the provision of transmission and interconnection facilities; (e). the constraints on the transmission system likely to result from the proposed generation facility/co-generation facility/power plant and the costs of the transmission system expansion required to remove such constraints; (f). the short-term and the long-term forecasts for additional capacity requirements; (g). the tariffs resulting or likely to result from the construction or operation of the proposed generation facility/co-generation facility/power plant; and (h). the optimum utilization of various sites in the context of both the short-term and the long-term requirements of the electric power industry as a whole.

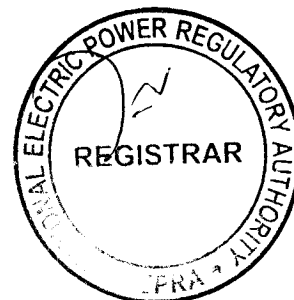

(ix). The proposed project will result in optimum utilization of the RE which was earlier untapped, resulting in pollution free electric power. It is pertinent to mention that Bagasse is an indigenous fuel and such fuels have a preference for the energy security. It is pertinent to mention that the Authority through its determination No. NEPRA/R/TRF-UTB-2013/5152-54, dated May 29, 2013 announced an upfront levelized tariff for the future Bagasse projects which works out to be Pak. Rs. 10.4078/kWh which is very competitive considering the fact that not only cheap electric power will be generated but it will utilize the Bagasse and other Biomass which is otherwise burnt causing air and soil pollution.

(x). As explained at Para-D(vi) above, the sponsors of the project carried out the grid interconnection study which concludes that the project will not face any constraints in transmission system. Further, being located at reasonable distance from the thick population, the project will not result in costs and right-of-way issues for the provision of transmission and interconnection facilities. It is pertinent to mention that MEPCO has included the project in its mid and long-term forecasts for additional capacity requirements. In view of the explanation give above, it is clear that the project fulfills the requirements of the Least Cost Option Criteria. In view of the clarification and justifications given above, the Authority is of the considered view that the project of BPREL fulfills the eligibility criteria for grant of generation licence as stipulated in the NEPRA Act, rules and regulations and other applicable documents.

(xi). The Authority has considered the comments of the stakeholders and has observed that except AKLA, all the stakeholders have supported the grant of generation licence to BPREL. In this regard, the Authority has observed that AKLA while submitting its comments have referred to its previous correspondences made on different issues which have either been adjudicated and determination has been given or the issues are still under consideration of the Authority. It is pertinent to mention that in its specific comments in this particular case, AKLA has raised issues pertaining to (a). surplus capacity; (b) underutilization of power plants; and (c). induction of new power plants on

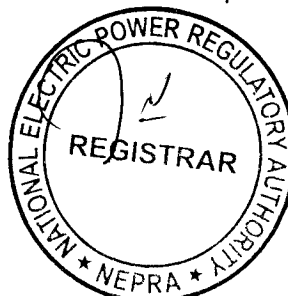

"Take or Pay basis" etc. Previously, on the comments of AKLA regarding said the issues, the Authority communicated specific clarification to AKLA in the matter through its letter No. NEPRA/SAT-I/TRF-100/17060, dated December 27, 2016. The Authority is of the considered opinion that actually there is considerable supply demand gap resulting in load-shedding and load management. This is strengthened from the fact that the proposed generation facility of BPREL is not only included in the future expansion plan of MEPCO but CPPA-G has also formally filed a power acquisition request for purchasing power from BPREL. In view of the said, the Authority does not consider it as a hindrance in the grant of generation licence to BPREL. Regarding the observations of AKLA that RE Projects should have "Take and Pay" tariff, the Authority hereby clarifies that it had already determined an upfront tariff which is on unit delivered basis therefore, the observations highlighted had already been taken into consideration. In view of the above, the observations of AKLA stand addressed.

(E). Grant of Generation Licence

(i). The sustainable and affordable energy/electricity is a key prerequisite for socio-economic development of any country. In fact, the economic growth of any country is directly linked with the availability of safe, secure, reliable and cheaper supply of energy/electricity. In view of the said reasons, the Authority is of the considered opinion that for sustainable development, all indigenous power generation resources including RE must be developed on priority basis.

(ii). The existing energy mix of the country is heavily skewed towards the thermal power plants, mainly operating on imported fossil fuel. The continuous import of fossil fuel not only creates pressure on the precious foreign exchange reserves of the country but is also an environmental concern. Therefore, in order to achieve sustainable development it is imperative that indigenous RE resources are given priority for power generation and their development is encouraged. The Energy Security Action Plan 2005 approved

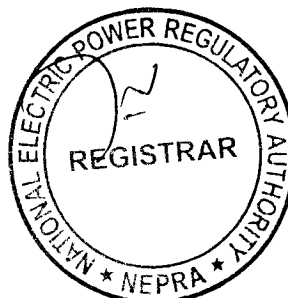

by the GoP, duly recognizes this very aspect of power generation through RE and envisages that at least 5% of total national power generation capacity (i.e. 9700 MW) to be met through RE resources by 2030.

(iii). The Authority considers that the proposed project of BPREL is consistent with the provisions of Energy Security Action Plan 2005. The project will help in diversifying the energy portfolio of the country. Further, it will not only enhance the energy security of the country by reducing the dependence on imported fuel but will also help in reducing carbon emissions by generating clean electricity, thus improving the environment.

(iv). As explained at Para-D(viii) above, BPREL has provided the details of location, technology, size, net capacity/energy yield, interconnection arrangements, technical details and other related information for the proposed generation facility/co-generation facility/power plant. In this regard, the Authority has observed that sponsors of the project have acquired approximately twenty two (22) acres of land for setting up the generation facility/co-generation facility/power plant. The said details have been incorporated in Schedule-I of the proposed generation licence. In this regard, the Authority directs BPREL to bring in its notice if there is any change in the same.

(v). The term of a generation licence under Rule-(5)(1) of the Generation Rules is required to match with the maximum expected life of the units comprised in a generating facility. According to the information provided by BPREL, the COD of the proposed generation facility/co-generation facility/power plant will be April 30, 2019 and it will have a useful life of more than thirty (30) years from its COD. In this regard, BPREL has requested that the term of the proposed generation licence may be fixed to thirty (30) years in consistent with the term of the proposed Energy Purchase Agreement (EPA) to be signed with the power purchaser. The Authority considers that said submission of BPREL about the useful life of the generation facility/co-generation facility/power plant and the subsequent request of BPREL to fix the

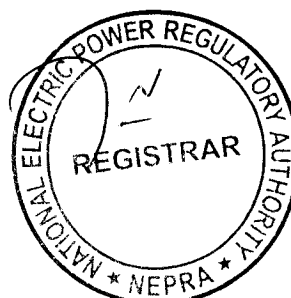

term of the generation licence is consistent with international benchmarks therefore, the Authority fixes the term of the generation licence to thirty (30) years from COD of the project.

(vi). Regarding the tariff, it is hereby clarified that under Section-7(3)(a) of the NEPRA Act, determining tariff, rate and charges etc. is the sole prerogative of the Authority. As explained at Para-D(v) above, the project is being developed in terms of the upfront tariff for Bagasse based projects, announced vide determination of the Authority No. NEPRA/R/TRF-UTB-2013/5152-54, dated May 29, 2013. In this regard, BPREL has already submitted an application for acceptance of the said upfront tariff. The Authority has admitted the application and the same is in advance stage of processing. Notwithstanding the said, the Authority through Article-6 of the generation licence directs BPREL to charge the power purchaser only such tariff which has been determined, approved or specified by the Authority. Further, the Authority directs BPREL to adhere to the provision of the said article of the generation licence in letter and spirit without any exception.

(vii). Regarding compliance with the environmental standards, the Authority directs BPREL to ensure that the project will comply with the environmental standards during the term of the generation licence. In view of the said, the Authority has included a separate article (i.e. Article-10) in the generation licence along with other terms and conditions that the licensee will comply with relevant environmental standards. Further, the Authority directs BPREL to submit a report on a bi-annual basis, confirming that operation of its project is compliant with required environmental standards as prescribed by the concerned environmental protection agency.

(viii). The proposed generation facility/co-generation facility/power plant of BPREL will be using RE resource for generation of electric power. Therefore, the project may qualify for the carbon credits under the Kyoto Protocol. Under the said protocol, projects coming into operation up to the year 2020 can qualify for the carbon credits. BPREL has informed that the project will achieve COD





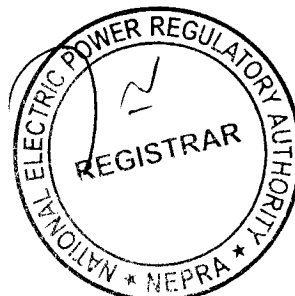

by April 30, 2019 which is within the deadline of the Koyoto Protocol. In view of the said, an article (i.e. Article-12) for carbon credits and its sharing with the power purchaser has been included in the generation licence. Foregoing in view, the Authority directs BPREL to initiate the process in this regard at the earliest so that proceeds for the carbon credits are materialized. BPREL will be required to share the proceeds of the carbon credits with the power purchaser as stipulated in Article-12 of the generation licence.

(ix). The Authority has observed that proposed generation facility/co-generation facility/power plant of BPREL will be supplying to the power purchaser approximately 25.00 MW and 27.00 MW of clean electric power during crushing and off season respectively. In addition to supplying the national grid, BPREL also plans supplying to ASML to the tune of 3.00 MW to 1.00 MW during crushing season and off season on mutually agreed rates. Regarding supply to ASML, the Authority observes that both ASML and BPREL are located within the same premises. Further, ASML will be supplied through one (01) underground Cable of 11 KV voltage (measuring about 500 meters) not involving any public or third party property. Further, the load of ASML is above the minimum level (1.00 MW) to qualify as a Bulk Power Consumer (BPC) under the Act. Pursuant to Section-21 of the Act, the Authority is empowered to allow a generation company to sell electric power to a BPC located in the service territory of a distribution company. In view of the said explanation, the Authority agrees to the proposed arrangement and allows BPREL to sell electricity to ASML. Further, under Section-2(v) of the NEPRA Act, ownership, operation, management and control of distribution facilities located on private property and used solely to move or deliver electric power to the person owning, operating, managing and controlling those facilities or to tenants thereof has not been included in the definition of "distribution". Based on the said considerations that the proposed BPC in the name of ASML is located within the same premises and no public area is involved, the supply of power to ASML by BPREL does not constitute a distribution activity under the Act, and BPREL will not require a distribution licence for supplying to ASML.

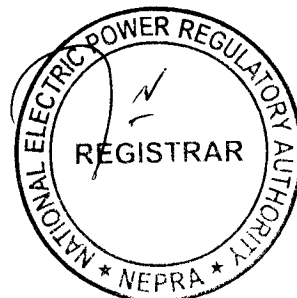

The matter of rates, charges and terms and conditions of tariff between BPREL and its BPC (i.e. ASML), does not affect any other consumer or third party. Therefore for the purpose of tariff, the Authority directs BPREL and ASML to agree on a bilateral agreement regarding tariff to be charged from ASML.

(x). In view of the above, the Authority hereby approves the grant of generation licence to BPREL on the terms and conditions set out in the generation licence annexed to this determination. The grant of generation licence will be subject to the provisions contained in the NEPRA Act, relevant rules, regulations framed thereunder and other applicable documents.

Authority:

Maj. (R) Haroon Rashid
(Member)

[Handwritten Signature]
28/4/17

Syed Masood-ul-Hassan Naqvi
(Member)

[Handwritten Signature]
28/4/17

Himayat Ullah Khan
(Member)

[Handwritten Signature]

Saif Ullah Chattha
(Member/Vice Chairman)

[Handwritten Signature]

Tariq Saddozai
(Chairman)

28.4.2017
— ON TOUR —

[Handwritten Signature]
2-5-17



**National Electric Power Regulatory Authority
(NEPRA)
Islamabad – Pakistan**

GENERATION LICENCE

No. IGSP/L/77/2017

In exercise of the powers conferred upon under Section-15 of the Regulation of Generation, Transmission and Distribution of Electric Power Act, 1997, the Authority hereby grants a Generation Licence to:

BAHAWALPUR ENERGY LIMITED

Incorporated Under the Companies Ordinance 1984 (XL VII of 1984) Having Corporate Universal Identification No. 0103439, dated November 08, 2016

for its Bagasse based Generation Facility/Co-Generation Power Plant Located at Ashrafabad, Tehsil & District Bahawalpur in the Province of Punjab

(Total Installed Capacity: 31.20 MW Gross ISO)

to engage in generation business subject to and in accordance with the Articles of this Licence.

Given under my hand this on 2nd day of May Two Thousand & Seventeen and expires on 29th day of April Two Thousand & Forty Nine.



Registrar



Article-1
Definitions

1.1 In this licence

- (a). "Act" means the Regulation of Generation, Transmission and Distribution of Electric Power Act, 1997 as amended or replaced from time to time;
- (b). "AEDB" means the Alternate Energy Development Board or any other entity created for the like purpose established by the GoP to facilitate, promote and encourage development of renewable energy in the country;
- (c). "Applicable Documents" mean the Act, the rules and regulations framed by the Authority under the Act, any documents or instruments issued or determinations made by the Authority under any of the foregoing or pursuant to the exercise of its powers under the Act, the Grid Code, the applicable Distribution Code, if any, or the documents or instruments made by the Licensee pursuant to its generation licence, in each case of a binding nature applicable to the Licensee or, where applicable, to its affiliates and to which the Licensee or any of its affiliates may be subject;
- (d). "Applicable Law" means the Act, relevant rules and regulations made there under and all the Applicable Documents;
- (e). "Authority" means the National Electric Power Regulatory Authority constituted under Section-3 of the Act;

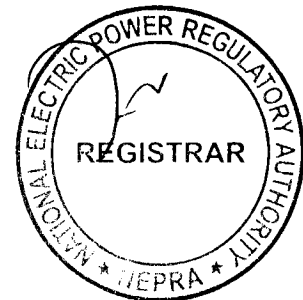

- (f). "Bulk Power Consumer (BPC)" means a consumer which purchases or receives electric power, at one premises, in an amount of one (01) megawatt or more or in such other amount and voltage level and with such other characteristics as the Authority may determine and the Authority may determine different amounts and voltage levels and with such other characteristics for different areas;
- (g). "Bus Bar" means a system of conductors in the generation facility/Co-Generation Facility/Power Plant of the Licensee on which the electric power from all the generators is collected for supplying to the Power Purchaser or BPC;
- (h). "Carbon Credits" mean the amount of Carbon Dioxide (CO₂) and other greenhouse gases not produced as a result of generation of energy by the generation facility/Co-Generation Facility/Power Plant and other environmental air quality credits and related emissions reduction credits or benefits (economic or otherwise) related to the generation of energy by the generation facility/Co-Generation Facility/Power Plant, which are available or can be obtained in relation to the generation facility/Co-Generation Facility/Power Plant after the COD;
- (i). "Co-Generation Facility/Power Plant" means the generation facility for simultaneous production of both electric power and heat or steam for industrial processes from a common fuel source;
- (j). "Commercial Operations Date (COD)" means the day immediately following the date on which the generation facility/Co-Generation Facility/Power Plant of the Licensee is commissioned;
- (k). "CPPA-G" means Central Power Purchasing Agency (Guarantee) Limited or any other entity created for the like purpose;

✓

✓

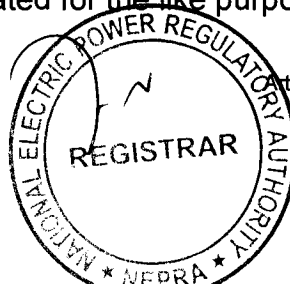

- (l). "Distribution Code" means the distribution code prepared by the concerned XW-DISCO and approved by the Authority, as it may be revised from time to time with necessary approval of the Authority;
- (m). "Energy Purchase Agreement (EPA)" means the energy purchase agreement, entered or to be entered into by and between the Power Purchaser and the Licensee, for the purchase and sale of electric energy generated by the generation facility/Co-Generation Facility/Power Plant, as may be amended by the parties thereto from time to time;
- (n). "Generation Rules" mean the National Electric Power Regulatory Authority Licensing (Generation) Rules, 2000 as amended or replaced from time to time;
- (o). "Grid Code" means the grid code prepared by NTDC and approved by the Authority, as it may be revised from time to time by NTDC with necessary approval by the Authority;
- (p). "GoP" means the Government of Pakistan acting through the AEDB which has issued or will be issuing to the Licensee a LoS for the design, engineering, construction, insuring, commissioning, operation and maintenance of the generation facility/Co-Generation Facility/Power Plant and has signed or will be signing an IA with the Licensee;
- (q). "IEC" means the International Electrotechnical Commission or its successors or permitted assigns;
- (r). "IEEE" means the Institute of Electrical and Electronics Engineers or its successors or permitted assigns;





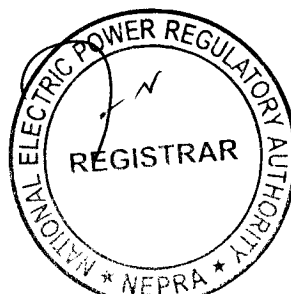

- (s). "Implementation Agreement (IA)" means the implementation agreement signed or to be signed between the GoP and the Licensee in relation to this particular generation facility/Co-Generation Facility/Power Plant, as may be amended from time to time;
- (t). "Letter of Support (LoS)" means the letter of support issued or to be issued by the GoP through the AEDB to the Licensee;
- (u). "Licensee" means **BAHAWALPUR ENERGY LIMITED** or its successors or permitted assigns;
- (v). "Licensing Regulations" mean the National Electric Power Regulatory Authority Licensing (Application & Modification Procedure) Regulations, 1999 as amended or replaced from time to time;
- (w). "MEPCO" means Multan Electric Power Company Limited or its successors or permitted assigns;
- (x). "NTDC" means National Transmission and Despatch Company Limited or its successors or permitted assigns;
- (y). "Policy" means the Policy for Development of Renewable Energy for Power Generation, 2006 of GoP as amended from time to time;
- (z). "Power Purchaser" means CPPA-G which will be purchasing electric power from the Licensee either on behalf of all XW-DISCOs or any single XW-DISCO, pursuant to the EPA for procurement of electric power;
- (aa). "XW-DISCO" means "an ex-WAPDA distribution company engaged in the distribution of electric power".

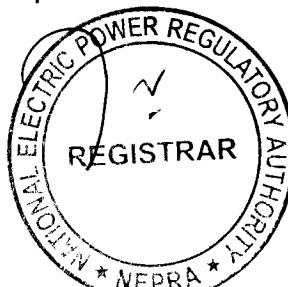

1.2 Words and expressions used but not defined herein bear the meaning given thereto in the Act or rules and regulations issued under the Act.

Article-2
Applicability of Law

This licence is issued subject to the provisions of the Applicable Law, as amended from time to time.

Article-3
Generation Facilities

3.1 The location, size (capacity in MW), technology, interconnection arrangements, technical limits, technical functional specifications and other details specific to the generation facility/Co-Generation Facility/Power Plant of the Licensee are set out in Schedule-I of this licence.

3.2 The net capacity of the generation facility/Co-Generation Facility/Power Plant of the Licensee is set out in Schedule-II hereto. The Licensee shall provide the final arrangement, technical and financial specifications and other specific details pertaining to its generation facility/Co-Generation Facility/Power Plant before its COD.

Article-4
Term of Licence

4.1 This licence shall become effective from the date of its issuance and will have a term of thirty (30) years from the COD of the generation facility/Co-Generation Facility/Power Plant of the Licensee.

4.2 Unless suspended or revoked earlier, the Licensee may apply for renewal of this licence ninety (90) days prior to the expiry of the above term, as stipulated in the Licensing Regulations.

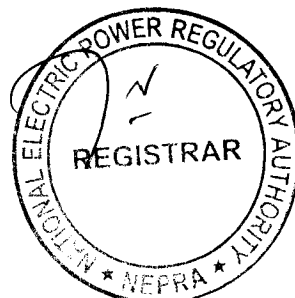

Article-5
Licence fee

The Licensee shall pay to the Authority the Licence fee as stipulated in the National Electric Power Regulatory Authority (Fees) Rules, 2002 as amended or replaced from time to time.

Article-6
Tariff

The Licensee shall charge the Power Purchaser only such tariff which has been determined, approved or specified by the Authority.

Article-7
Competitive Trading Arrangement

7.1 The Licensee shall participate in such manner as may be directed by the Authority from time to time for development of a Competitive Trading Arrangement. The Licensee shall in good faith work towards implementation and operation of the aforesaid Competitive Trading Arrangement in the manner and time period specified by the Authority. Provided that any such participation shall be subject to any contract entered into between the Licensee and another party with the approval of the Authority.

7.2 Any variation or modification in the above-mentioned contracts for allowing the parties thereto to participate wholly or partially in the Competitive Trading Arrangement shall be subject to mutual agreement of the parties thereto and such terms and conditions as may be approved by the Authority.

Article-8
Maintenance of Records

For the purpose of sub-rule (1) of Rule-19 of the Generation Rules, copies of records and data shall be retained in standard and electronic form and all such records and data shall, subject to just claims of confidentiality, be accessible by authorized officers of the Authority.

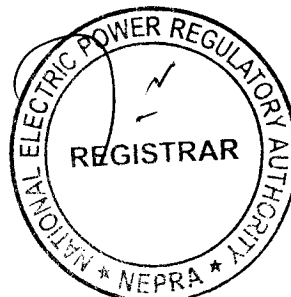

Article-9
Compliance with Performance Standards

The Licensee shall comply with the relevant provisions of the National Electric Power Regulatory Authority Performance Standards (Generation) Rules 2009 as amended from time to time.

Article-10
Compliance with Environmental & Safety Standards

10.1 The generation facility/Co-Generation Facility/Power Plant of the Licensee shall comply with the environmental and safety standards as may be prescribed by the relevant competent authority from time to time.

10.2 The Licensee shall provide a certificate on a bi-annual basis, confirming that the operation of its generation facility/Co-Generation Facility/Power Plant is in conformity with required environmental standards as prescribed by the relevant competent authority.

Article-11
Provision of Information

In accordance with provisions of Section-44 of the Act, the Licensee shall be obligated to provide the required information in any form as desired by the Authority without any exception.

Article-12
Emissions Trading/Carbon Credits

The Licensee shall process and obtain expeditiously the Carbon Credits admissible to the generation facility/Co-Generation Facility/Power Plant. The Licensee shall share the said proceeds with the Power Purchaser as per the Policy.

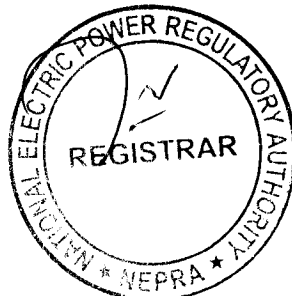

Article-13
Power off take Point and Voltage

The Licensee shall deliver the electric power to the Power Purchaser at the outgoing Bus Bar of its generation facility/Co-Generation Facility/Power Plant. The Licensee shall be responsible for the up-gradation (step up) of generation voltage up to the required dispersal voltage level.

Article-14
Design & Manufacturing Standards

The generation facility/Co-Generation Facility/Power Plant of the Licensee shall be designed, manufactured and tested according to the latest IEC, IEEE or other equivalent standards. All the plant and equipment of the generation facility/Co-Generation Facility/Power Plant shall be unused and brand new.

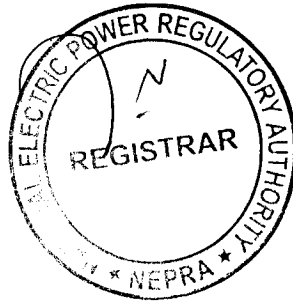

[Handwritten marks]

SCHEDULE-I

The Location, Size (i.e. Capacity in MW), Type of Technology, Interconnection Arrangements, Technical Limits, Technical/Functional Specifications and other details specific to the Generation Facilities of the Licensee are described in this Schedule.

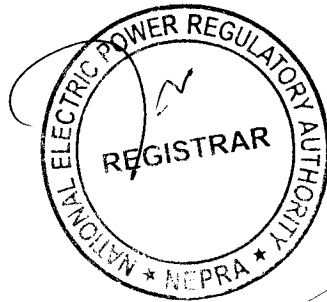

Handwritten initials or marks at the bottom left of the page.

Location of the
Generation Facility/Co-Generation Facility/Power Plant
of the Licensee on Map of Pakistan

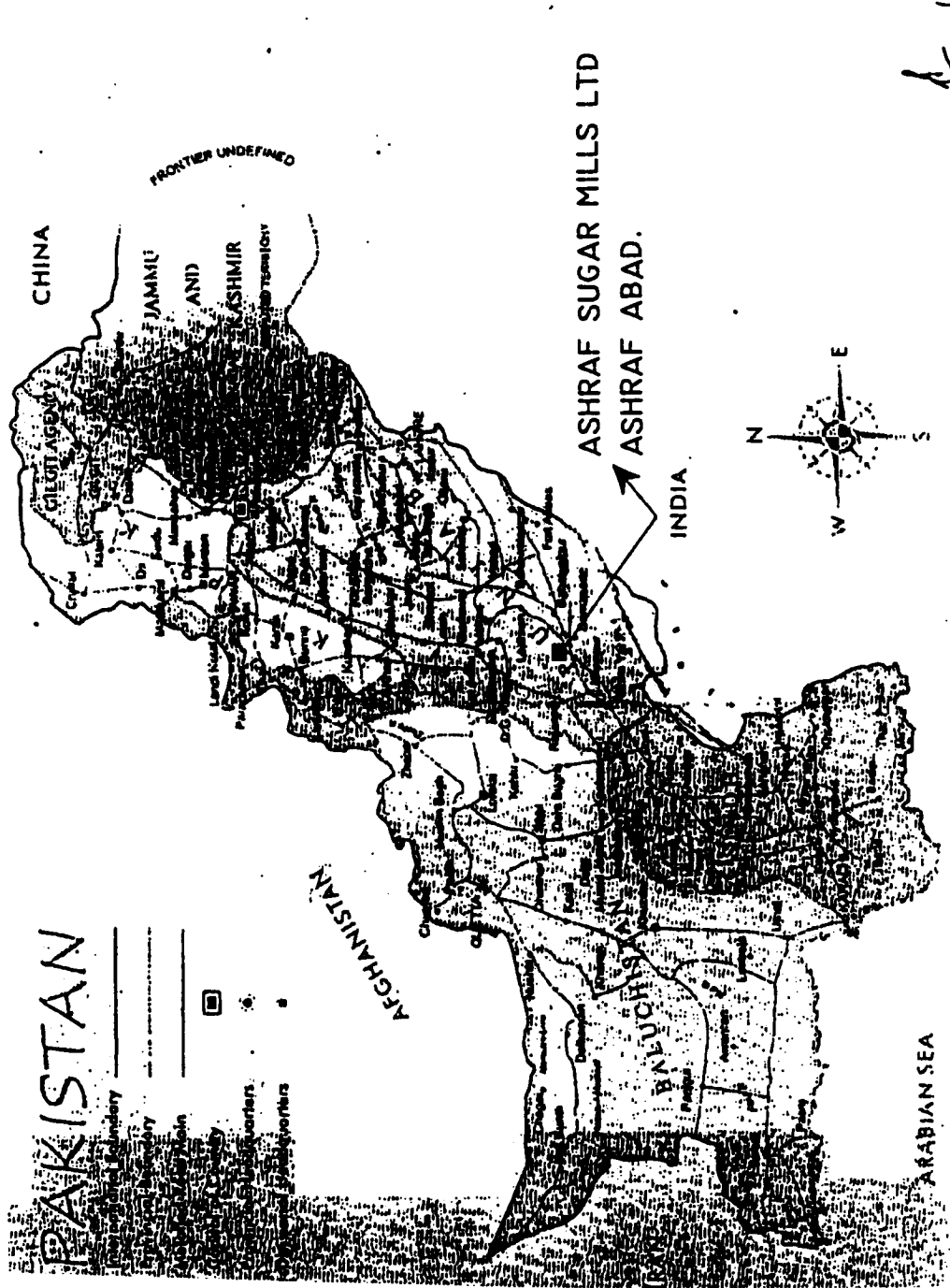

Handwritten marks: a signature and an arrow pointing towards the map.

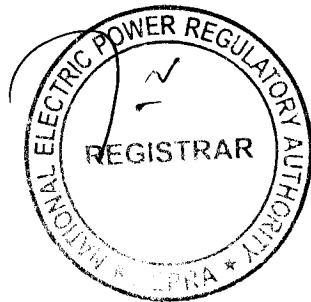

Process Diagram of the Generation Facility/Co-Generation Facility/Power Plant of the Licensee

Proposed Co-Generation
Scheme of Bahawalpur Energy Limited

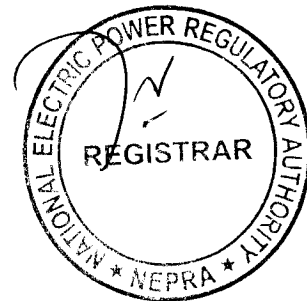
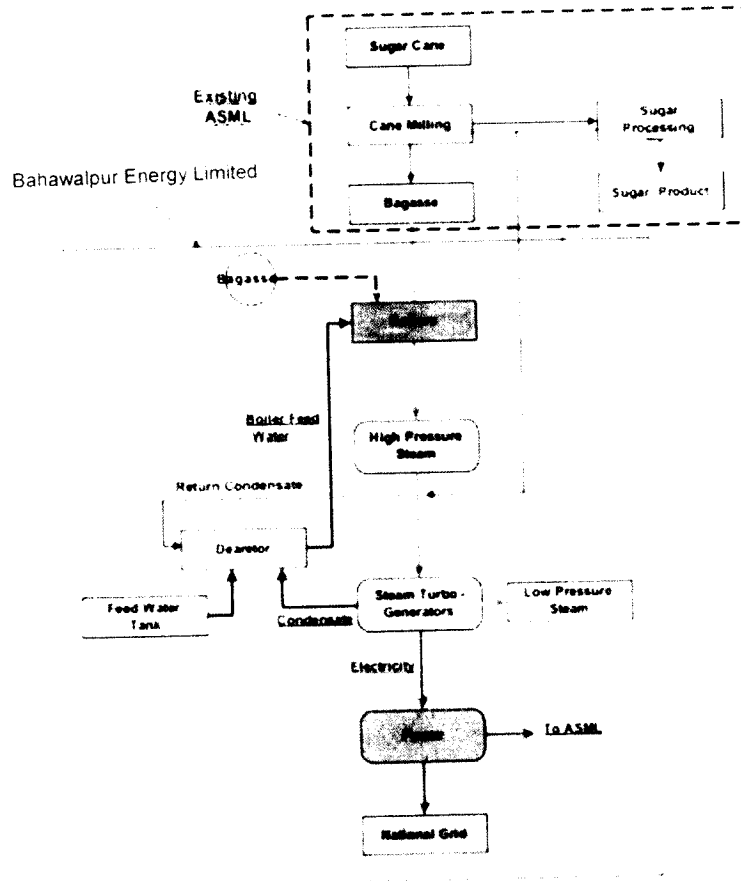

**Single line Diagram (Electrical) of the
Generation Facility/Co-Generation Facility/Power Plant
of the Licensee**

Single Line Diagram of 132/11 kV Busbar At Bahawalpur Energy Ltd. PP

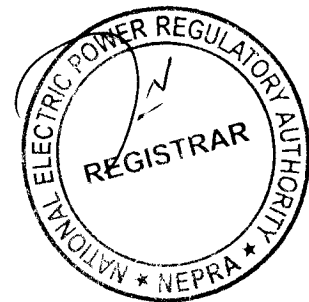
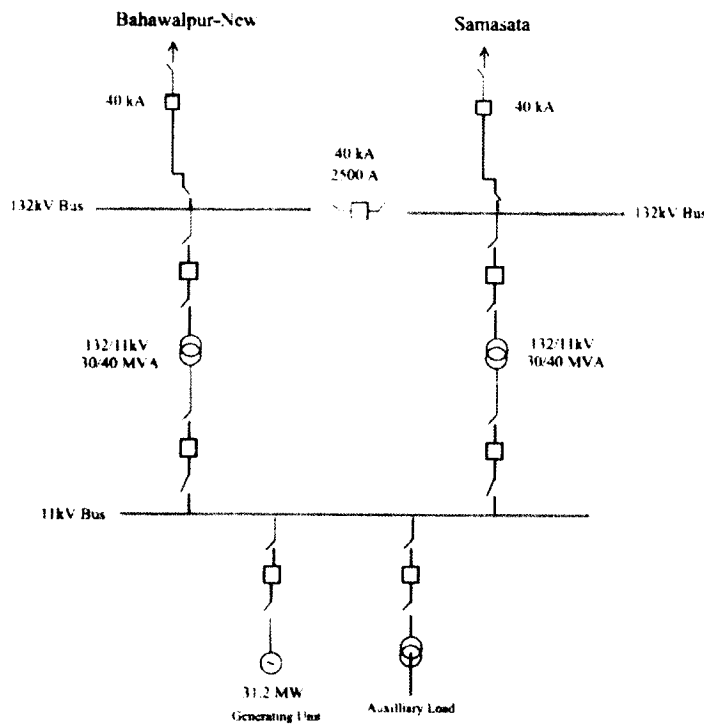

Handwritten marks and signatures, including a rectangular stamp and a signature.

Interconnection Arrangement for Dispersal of Electric Energy/Power from the Generation Facility/Co-Generation Facility/Power Plant

The electric energy/power from the Bagasse based Co-Generation Facility/Power Plant of Licensee will not only be supplied to a Bulk Power Consumer-BPC* (i.e. Ashraf Sugar Mills Limited-ASML as enumerated in this Schedule-I) but also to the load center of MEPCO.

(2). The interconnection facilities/transmission arrangement for supplying to MEPCO from the above mentioned generation facility shall be at 132 kV level. The dispersal/interconnection arrangement for supplying to MEPCO will be consisting of a 132 KV Double Circuit (D/C) Transmission Line (on ACSR LYNX Conductor) measuring about eight (08) Kilo-Meter for making an In-Out of 132 KV Bahawalpur (New)-Samma Satta Transmission Line connecting the generation facility/Co-Generation Facility/Power Plant to the network of MEPCO.

(3). The above dispersal arrangement is based on the approval of MEPCO regarding the Grid Interconnection Study. Any change in the above mentioned arrangement for dispersal of electric energy/power as agreed by the Licensee, MEPCO or the Power Purchaser shall be communicated to the Authority in due course of time.

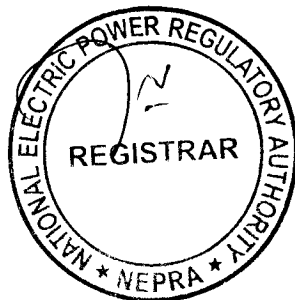



* The details pertaining to BPC, supply arrangement and other relating information is provided in the subsequent description of this Schedule-I.

**Details of the
Generation Facility/Co-Generation Facility/
Power Plant**

(A). General Information

(i).	Name of the Company/Licensee	Bahawalpur Energy Limited
(ii).	Registered Office of the Company	128 -Tufail Road, Lahore
(iii).	Business Address/ Office of the Company	-Do-
(iv).	Location of the Generation Facility	Ashrafabad, Tehsil & District Bahawalpur in the Province of Punjab
(v).	Type of the Generation Facility	Bagasse based, high-pressure generation facility/Co-Generation Facility/Thermal Power Plant.

(B). Configuration of Generation Facility

(i).	Installed Capacity/Size of the Generation Facility	31.20 MW.	
(ii).	Technology of the Generation Facility	Conventional Steam Turbine based Power Plant [1 x 31.20 MW extraction cum condensing Steam Turbine and One (01) Travelling grate bagasse fired boiler Operating at 110 bar (kg/cm ²) and Producing 160 Tons of Steam Per Hour-TPH].	
(iii).	Number of Units & Size of Each Unit of the Generation Facility	1 x 31.20 MW	
(iv).	Make/Model/Type/ Year of Manufacture Etc. of each Unit of the Generation Facility	Steam Turbine	Hangzhou Steam Turbine Co. Limited-HTC/ SKODA, SIEMENS or Equivalent.

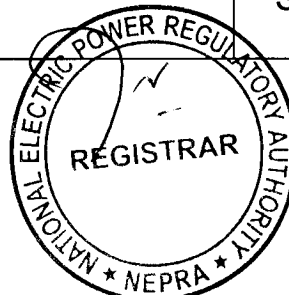

		Boiler	Travelling grate type Boiler 160 TPH Capacity and 110 bar(kg/cm ²) Wuxi Huaguang Boiler Co., Ltd China or Equivalent.
(v).	Expected/ Anticipated COD of the Generation Facility	April 30, 2019	
(vi).	Expected Useful Life of the Generation Facility from COD	30 Years (Minimum)	

(C). Fuel/Raw Material Details

(i).	Primary Fuel	Bagasse	
(ii).	Alternate Fuel	Biomass (Cane Trash, Rice Husk, Rice Straw Wheat Straw and Cotton Stalk etc.)	
(iii).	Fuel Source (Imported/Indigenous)	Primary Fuel	Alternate Fuel
		Indigenous	Indigenous
(iv).	Fuel Supplier	Primary Fuel	Alternate Fuel
		Ashraf Sugar Mills Limited- ASML(primary)/other Bagasse/Biomass suppliers (if available in the nearby area)	Biomass suppliers (if available in the nearby area of the Generation Facility)
(v).	Supply Arrangement	Primary Fuel	Alternate Fuel
		Through Conveyor Belts/Loading Trucks/Tractor Trolleys etc.	Through Conveyor Belts/Loading Trucks/Tractor Trolleys etc.

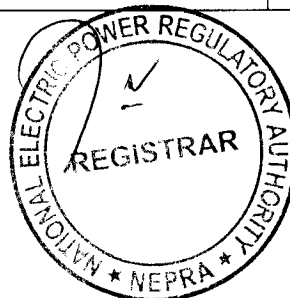

(vi).	Sugarcane Crushing Capacity	12,000 Ton per day	
(vii).	Bagasse Generation Capacity	3,600 Ton per day	
(viii).	Fuel Storage Facilities	Primary Fuel	Alternate Fuel
		Bulk Storage	Bulk Storage
(ix).	Gross Capacity of the Storage Facilities	Primary Fuel	Alternate Fuel
		100,000 Metric Tons bulk storage	Included as part of the Primary Fuel Storage

(D). Emission Values

		Primary Fuel	Alternate Fuel
(i).	SO _x	<264mg/Nm ³	<264mg/Nm ³
(ii).	NO _x	<100 mg/ Nm ³	<100 mg/ Nm ³
(iii).	CO ₂	11% -13%	11% -13%
(iv).	CO	<200mg/ Nm ³	<200mg/ Nm ³
(v).	PM ₁₀	<150mg/Nm ³	<150mg/Nm ³

(E). Cooling System

(i).	Cooling Water Source/Cycle	RCC Cooling tower of induced draft counter flow type. Make up water will be drawn from the bore wells/Closed Loop.
------	----------------------------	--

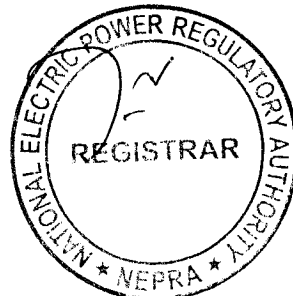

(F). Plant Characteristics

(i).	Generation Voltage	11.00 KV		
(ii).	Frequency	50 Hz		
(iii).	Power Factor	0.80 lagging - 0.90 leading		
(iv).	Automatic Generation Control (AGC)	Yes		
(v).	Ramping Rate	3.20 KW/Second		
(vi).	Time required to Synchronize to Grid	210 Minutes	120 Minutes	60 Minutes
		During cold start (i.e. when plant is started later than 72 hours after shutdown)	During warm start (i.e. when plant is started at less 36 hours after shutdown)	During Hot start (i.e. when plant is started at less than 12 hours after shutdown)

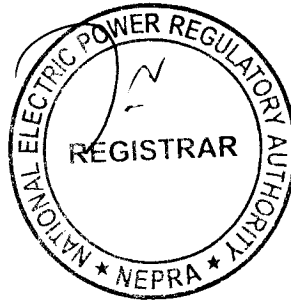

[Handwritten mark]

[Handwritten mark]

Information Regarding
Distribution Network for Supply of Power to Bulk Power Consumer
(in the Name of Ashraf Sugar Mills Limited-ASML)

(i).	No. of Feeders	01(One)
(ii).	Length of Each Feeder (Meter)	500 Meter (Approximately)
(iii).	Length of Each Feeder to each Consumer	500 Meter (One Feeder to ASML)
(iv).	In respect of all the Feeders, describe the property (streets, farms, Agri land, etc.) through, under or over which they pass right up to the premises of customer, whether they cross-over.	The 11 KV cable supplying power to ASML is located on private property owned by ASML, without crossing of any Public or third party Private Property etc.
(v).	Whether owned by BPREL, Consumer or MEPCO-(deal with each Feeder Separately)	
	(a). If owned by MEPCO, particulars of contractual arrangement	N/A
	(b). Operation and maintenance responsibility for each feeder	The Operation and Maintenance is the responsibility of ASML.
(vi).	Whether connection with network of MEPCO exists (whether active or not)- If yes, provide details of connection arrangements (both technical and contractual)	Yes/ASML is B-3 Consumer of MEPCO
(vii).	Any other network information deemed relevant for disclosure to or consideration of the Authority.	N/A

[Handwritten signature]

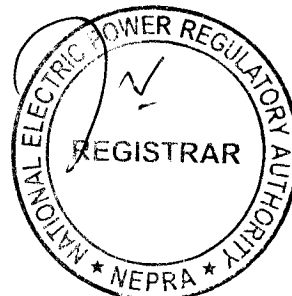

Information Regarding
Distribution Network for Supply of Electric Power to Bulk Power
Consumer to be Supplied By the Licensee

(i).	No. of Consumers	One (01)	
(ii).	Location of consumers (distance and/or identity of premises)	Ashrafabad, Tehsil & District Bahawalpur, in the Province of Punjab	
(iii).	Contracted Capacity and Load Factor for consumer	During Crushing Season	During Off Crushing Season
		03.00 MW (Max)	01.00 MW (Max)
(iv).	Specify Whether		
	(a).	The consumer is an Associate undertaking of the BPREL-If yes, specify percentage ownership of equity;	ASML and BPREL are group companies of the Ashraf Group of Industries.
	(b).	There are common directorships:	No
	(c).	Either can exercise influence or control over the other.	No
(v).	Specify nature of contractual Relationship		
	(a).	Between each consumer and BPREL.	ASML and BPREL are group companies of the Ashraf Group of Industries/Supply of Electricity on Continuous basis
	(b).	Consumer and MEPCO.	ASML is B-3 Consumer of MEPCO
(vi)	Any other network information deemed relevant for disclosure to or consideration of the Authority.	N/A	

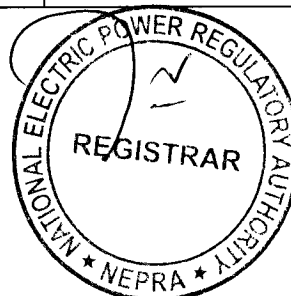

SCHEDULE-II

The Installed/ISO Capacity (MW), De-Rated Capacity at Mean Site Conditions (MW), Auxiliary Consumption (MW) and the Net Capacity At Mean Site Conditions (MW) of the Generation Facilities of Licensee are given in this Schedule

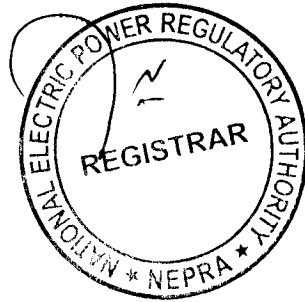

[Handwritten marks]

SCHEDULE-II

		<u>Season Operation</u>	<u>Off-Season Operation</u>
(1).	Total Installed Capacity of the Generation Facility	31.20 MW	31.20 MW
(2).	De-rated Capacity of Generation Facility at Reference Site Conditions	31.20 MW	31.20 MW
(3).	Auxiliary Consumption of the Generation Facility	03.20 MW	03.20 MW
(4).	Maximum Electric Power to be Supplied to Bulk Power Consumer (i.e. Ashraf Sugar Mills Limited-ASML) from the Generation Facility at Reference Site Condition	03.00 MW	01.00 MW
(5).	Total Net Capacity of Generation Facility at Reference Site Condition	25.00 MW	27.00 MW

Note

All the above figures are indicative as provided by the licensee. The net capacity available to Power Purchaser for dispatch will be determined through procedure(s) contained in the Energy Purchase Agreement or any other Applicable Document(s).

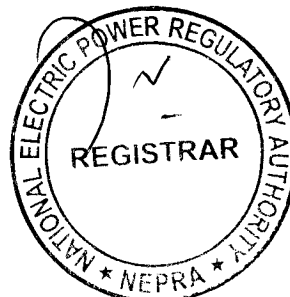

Authorization
by National Electric Power Regulatory Authority (NEPRA) to
Bahawalpur Energy Limited

Incorporated Under the Companies
Ordinance 1984 (XL VII of 1984) Having Corporate Universal
Identification No. 0103439, dated November 08, 2016

For
Sale to Bulk Power Consumer

Pursuant to Section-21 of the Act and Rule-7 of the NEPRA Licensing (Generation) Rules-2000, the Authority hereby authorizes Bahawalpur Energy Limited-BPREL (the Licensee) to engage in second-tier supply business, limited to the following consumers:-

(a). Ashraf Sugar Mills Limited

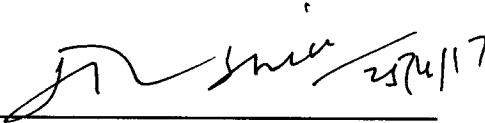

Maj. (R) Haroon Rashid
(Member)

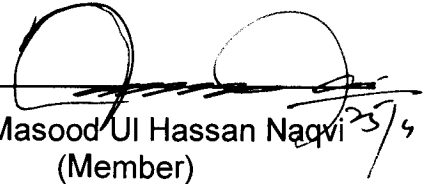

Syed Masood Ul Hassan Naqvi
(Member)



Himayat Ullah Khan
(Member)

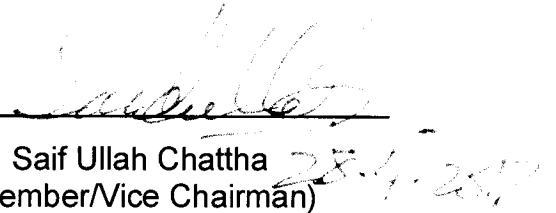

Saif Ullah Chattha
(Member/Vice Chairman)

— ON TOUR —

Tariq Saddozai
(Chairman)

